

Budd Silverliner II Frames and Truck Installation

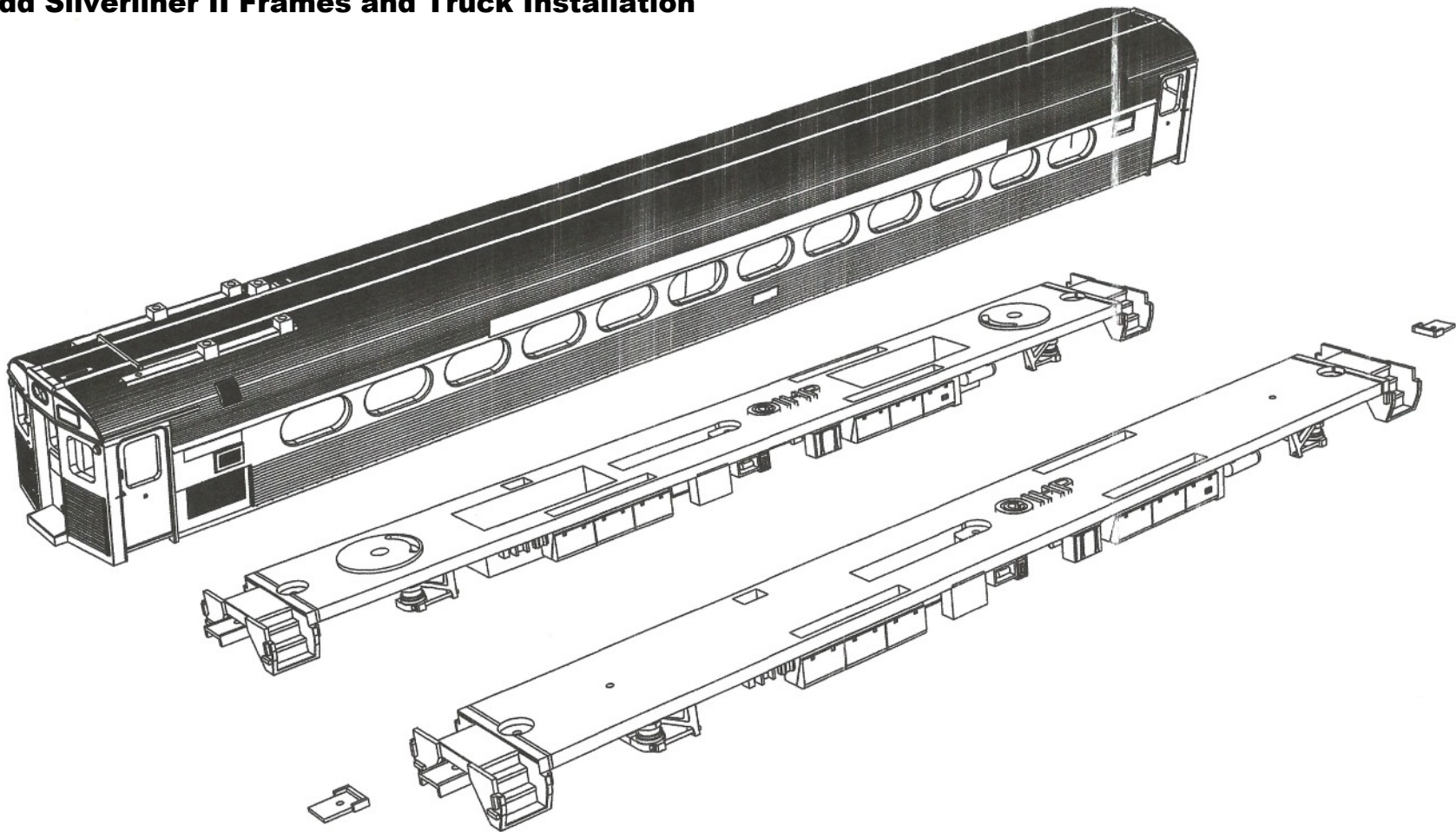

Note orientation of frame when installed in body. The frame is installed by means of three 2-56 screws (included with shell). Trucks are screwed in place on nonpowered frame. Drill bolster holes for 2-56 screws (not included). You'll need two 2-56 screws and two 2-56 washers to hold the trucks in place. Make sure the trucks can move freely and with just enough lateral movement at one end to allow for rough track and grades.

For powered cars, use NWSL Stanton Drive. The frame can use one or two powered trucks. They screw in place from the top. The two wells by each bolster can be used to add a little extra weight for improved traction. Do not overweigh, or you can overtax the power truck and distort the frame.

Coupler covers are held in place by two 2-56 screws (not included). Pockets can use Kadee or EZ-Mate couplers.